

KATALÓG ŽIAROVIEK pre zdravotníctvo

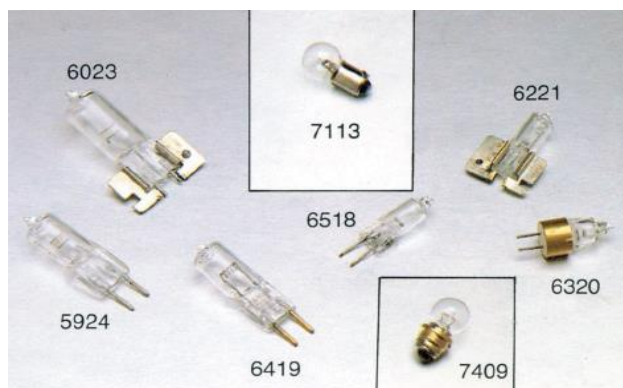

2014



Nexa, s.r.o. - výroba a predaj zdravotnickej techniky www.nexa.eu



Sasinkova 9, P.O. BOXE 15, 921 41 Piešťany tel: 033/7730591,2,3 fax: 033/7730594 mobil: +421 905 279 057 / 0908 248 928 e-mail: nexa@nexa.eu

Vážení zákazníci!

Firma Nexa, s.r.o., zaoberajúca sa výrobou, predajom a servisom zdravotníckej techniky si Vám dovoľuje ponúknuť široký sortiment žiaroviek používaných v zdravotníctve. Katalóg našej firmy Vám predkladá viacero skupín žiaroviek, ako napríklad pre operačné lampy, mikroskopy, oftalmoskopy, laryngoskopy, retinoskopy, otoskopy, negatoskopy, endoskopy, analyzátory, germicídne žiariče - UVC, infra a UVA-B oblasť, vytvrdzovacie lampy a iné. Katalóg predstavuje len základný sortiment. V ponuke sú ďalšie špeciálne žiarovky a výbojky.

Každá žiarovka je špecifikovaná hlavnými parametrami Volt [V], Watt [W], svietivosť [lm], životnosť [h], päťica, objednávacie číslo, typ a kód.

Pre ľahšiu identifikáciu je pri každej žiarovke uvedený obrázok a jej rozmerový náčrtok. Pri identifikácii je mnohokrát veľmi dôležitý rozmer a tvar vlákna, veľkosť banky a päťica. Práve tieto parametre možno podľa predkladaného katalógu ľahšie identifikovať. Žiarovky sú dodávané priamo od renomovaných výrobcov ako **PHILIPS, OSRAM, TUNSGRAM, NARVA, GUERRA, RADIUM, ORBITEC, RALUTEC** a iné. Okrem žiaroviek uvádzaných v tomto katalógu Vám naša firma pomôže aj so zaistením iných, atypických žiaroviek.

V prípade Vášho záujmu uvádzajte nasledovné údaje:

- poradové číslo
- napätie, výkon
- (ak je potrebné svietivosť, životnosť)
- číslo obrázku
- päťicu

Dodacie podmienky:

dodávky žiaroviek zákazníkom kuriérom do 24 hodín

Dodacie lehoty:

bežné typy skladom, inak dodacia lehota 2-4 týždne

Platobné podmienky:

prevodným príkazom, na dobierku, alebo podľa dohody so zákazníkom

Veríme, že naša ponuka pomôže vyriešiť Vaše problémy. V prípade záujmu nás prosím kontaktujte telefonicky, alebo e-mailom.

Tel: 033/7730591,2,3 fax: 033/7730594 mobil: +421 905 279 057 / 0908 248 928 e-mail: nexa@nexa.eu

OBJ. ČÍSLO	KÓD	Typ	VOLT [V]	WATT [W]	PÁČICA	SVIETIVOSŤ [lm]	ŽIVOTNOSŤ [h]	OBRÁZOK č.
1.	0079/0	H016544	24	40	BX22D	500	600	1
2.	0079/1	H016678	24	50	BX22D	600	600	1
3.	0079/2	H018251	220	50	BX22D	450	500.	1
4.	0079/3	H018250	220	50	BX22D	400	500	1
5.	0079/4	H018253	240	50	BX22D	450	500	1
6.	0079/5	H016578	125	50	BX22D	400	460	1
7.	0079/6	H016679	110	50	BX22D	400	440	1
8.	0178/CH		24	40	BA15D	500	600	2
9.	0178/3	A.5904	24	40	BA15D	500	600	2
10.	0178/4	A.5905	24	50	BA15D	600	600	2
11.	0178/5	H016344	125	30	BA15D	280	500	2
12.	0178/6	-	230	40	BA15D	400	500	2
13.	0178/FA	-	24	35	BA15D	600	1000	3
14.	0178/3F	-	24	40	BA15D	500	600	4
15.	0178/L1	3706	24	40	BA15D	500	600	5
16.	0178/L5	-	24	50	BA15D	600	600	5
17.	0277/4	-	24	40	BA15D	500	600	6
18.	0277/5	A.5901	24	50	BA15D	600	600	6
19.	0376/CH	-	24	25	BA15D	450	500	7
20.	0376/1	H016164	24	25	BA15D	450	500	7
21.	0376/2	A.6004	24	30	BA15D	450	600	7
22.	0376/4	H016372	24	40	BA15D	500	600	7
23.	0376/6	-	24	50	BA15D	600	600	7
24.	0376/7	H016191	12	25	BA15D	370	400	7
25.	0376/9	R.16192	12	35	BA15D	400	400	7
26.	0376/11	H016170	110	30	BA15D	300	500	7
27.	0574/1	-	12	35	BA15D	400	400	8
28.	0574/3	H018550	24	40	BA15D	500	600	8
29.	0772/G1	GAL/Z	12	25	P45T	400	300	9
30.	0772/G4	GAL/Z	24	1,4A.	P45T	500	300	9
31.	0772/L3	L99	24	1,4A.	P45T	500	300	9
32.	0772/L5	58912	24	50	P45T	860	2000	10
33.	0772/L6	58913	24	55	P45T	900	2000	10
34.	0772/L7	58911	24	21	P45T	400	500	10
35.	0772/L8	58911/A	24	25	P45T	480	800	10
36.	0772/L9	58911/B	24	35	P45T	630	1000	10

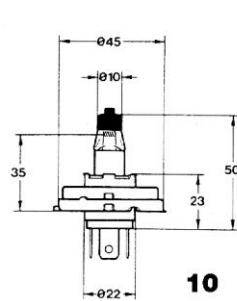
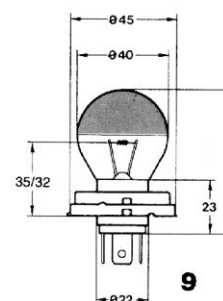
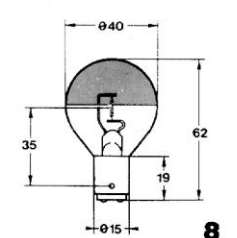
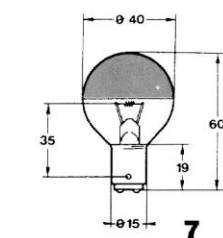
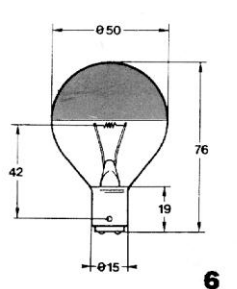
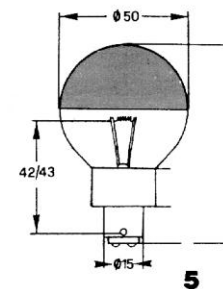
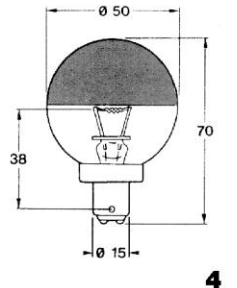
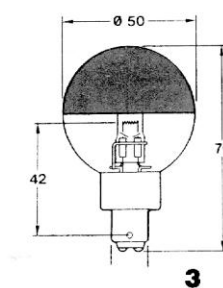
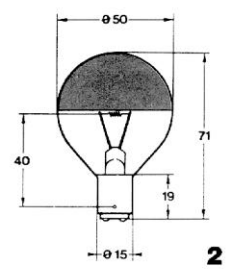
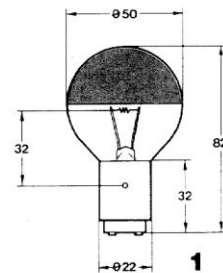

CH = ČÍRA

F = PRÍRUBA

A = HALOGEN

* = MATNÁ

OBJ. ČÍSLO	KÓD	TYP	VOLT [V]	WATT [W]	PĀTICA	SVIETIVOSŤ [lm]	ŽIVOTNOSŤ [h]	OBRÁZOK č.
------------	-----	-----	----------	----------	--------	-----------------	---------------	------------

37.	0871/CH	-	24	50	BA20D	600	700	11
38.	0871/2	-	24	50	BA20D	600	700	11
39.	0871/4	-	24	70	BA20D	700	400	11
40.	0871/6	-	12	70	BA20D	600	200	11
41.	0970/1	-	12	25	BA20D	400	300	12
42.	0970/CH	-	24	25	BA20D	450	700	12
43.	097083B	M8891602	24	25	BA20D	450	700	12
44.	0970/4	-	24	30	BA20D	500	700	12
45.	0970/7	M8891604	24	50	BA20D	600	700	12
46.	0970/8	-	24	60	BA20D	650	600	12
47.	0970/V1	M1521	24	60	BA20D	650	600	13
48.	0970/V2	-	24	50	BA20D	600	700	13
49.	8890/1	8891402	24	50/50	BA22D	-	1000	14
50.	8891/1	8891202	24	75/75	E27/30	-	1000	15
51.	8892/1	8891002	24	100/100	E27/30	-	1000	16
52.	8892/2	-	24	150	E27/30	-	300	17
53.	8892/3CH	-	24	150	E27/30	-	300	17
54.	8892/4 *	-	230	150	E27/30	-	1000	18

ISO 9001:2008, ISO 13485:2003

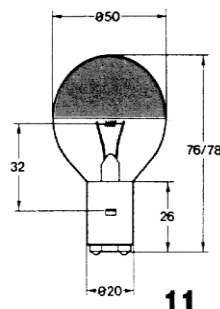

11

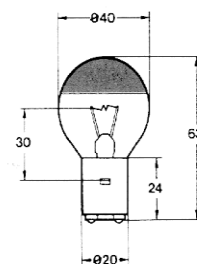

12

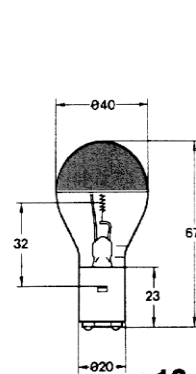

13

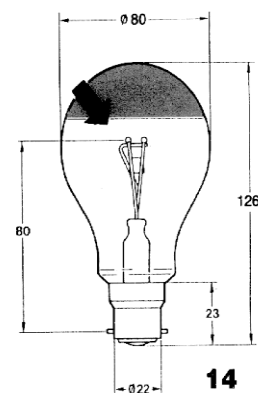

14

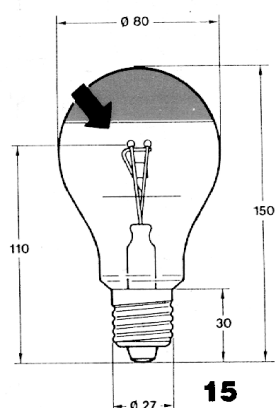

15

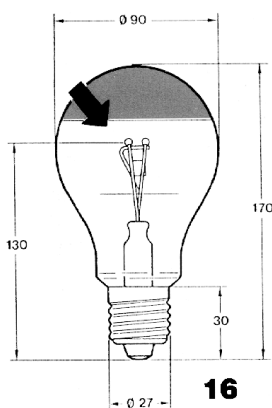
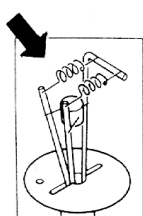

16

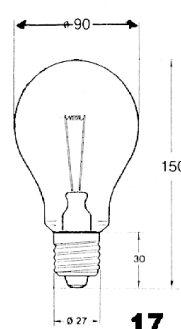

17

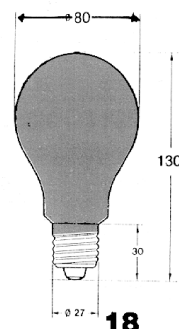

18

OBJ. ČÍSLO	KÓD	TYP	VOLT [V]	WATT [W]	PĀTICA	SVIETIVOSŤ [lm]	ŽIVOTNOSŤ [h]	OBRÁZOK č.
------------	-----	-----	----------	----------	--------	-----------------	---------------	------------

55.	8893/1	HCR145/3B	24	40	G16	500	1000	19
56.	8893/2	HCR 150/3S	24	40	G6	500	1000	19

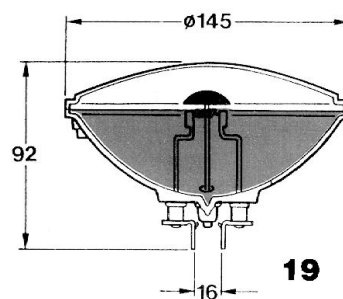

19

CH = ČĪRA

V = VERTIKAL

* = MATNĀ

OBJ. ČÍSLO	KÓD	TYP	VOLT [V]	WATT [W]	PÁTICA	SVIETIVOSŤ [lm]	ŽIVOTNOSŤ [h]	OBRÁZOK č.
57.	1168	GHAMBS	6	15	P415D	130	100	20
58.	1465/2H	0P.2120	6	33	BA15D	430	80	21
59.	1465/3	0P.2202	7	35	BA15D	460	100	21
60.	1565/1	-	6	15	BA15S	100	200	22
61.	1565/2	-	6	25	BA15S	160	300	22
62.	1565/4	5022	6	21	BA15S	140	300	22
63.	1566/2	-	6	25	BA15S	160	300	23
64.	1566/4	1361	12	25	BA15S	400	600	23
65.	1762/1	-	6	33	P3OS	430	80	24
66.	1762/AX	7582	12	25	P3OS	400	600	25
67.	1762/2	-	6	30	P3OD	330	100	26
68.	1762/H	-	7	35	P3OD	460	100	26
69.	1762/3	GE.1630	6	15	P3OD	130	100	27
70.	1762/4	GE.1520	6	15	P3OD	130	100	28
71.	1762/5	GE.1460X	6,5	2,75	P3OD	200	100	28
72.	1762/6	GE.1468X	6	4,5	P3OD	300	80	28
73.	1762/7	GE.1634	20	1A.	P3OD	140	200	28
74.	1763/1	5252012	12	25	P17S	370	300	28/A
75.	1763/2	568302	24	25	P17S	400	300	28/A

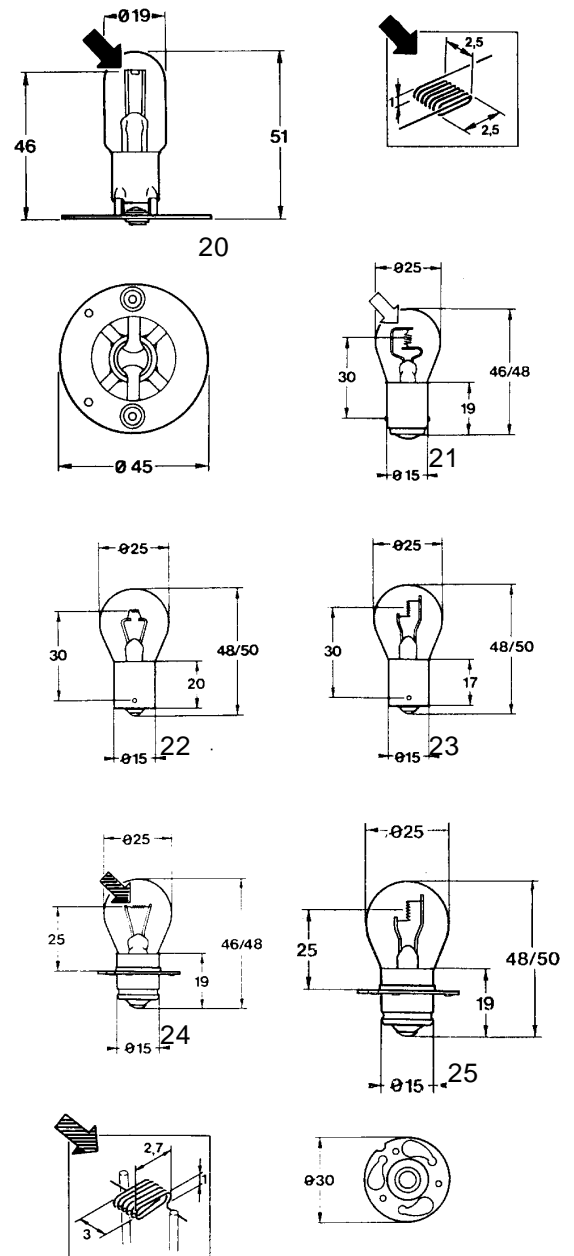

AX - AXIAL

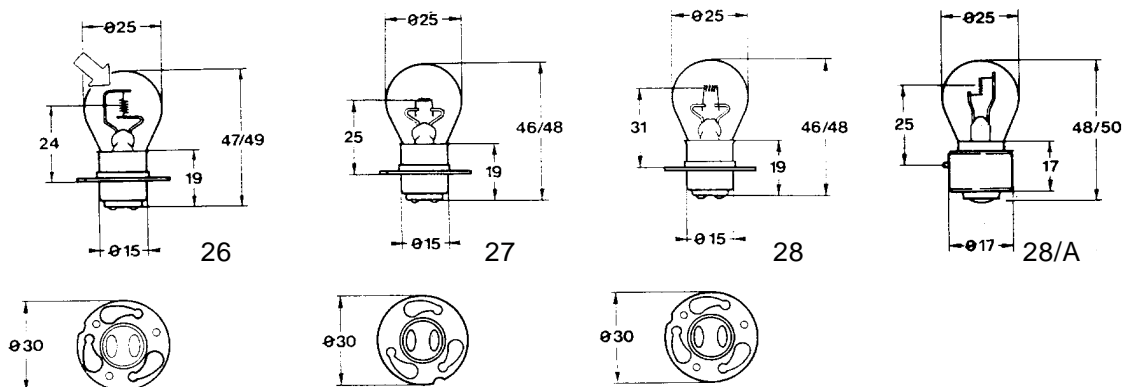

OBJ. ČÍSLO	KÓD	TYP	VOLT [V]	WATT [W]	PÁČICA	SVIETIVOSŤ [lm]	ŽIVOTNOSŤ [h]	OBRÁZOK č.
76.	1861/1	H 8001	6	4,5A	E14/16	360	100	29
77.	1861/3	-	6	50	E14/16	500	120	29
78.	1960/1	H5940-750	6	4,5A	P4OS	360	100	30
79.	2058/3	RX	24	50	BA20D	600	500	31
80.	2058/3 *	-	24	50	BA20D	500	450	31
81.	2158/1	H5900/930	6	4,5A	P445	360	100	32
82.	2756/1	5.4179	6	30	P27D	430	100	33
83.	2756/2	5.4130	12	30	P275	460	80	34
84.	2756/H	-	6	33	P285	430	80	35
85.	2756/NK	-	6	15	P25D	130	100	36

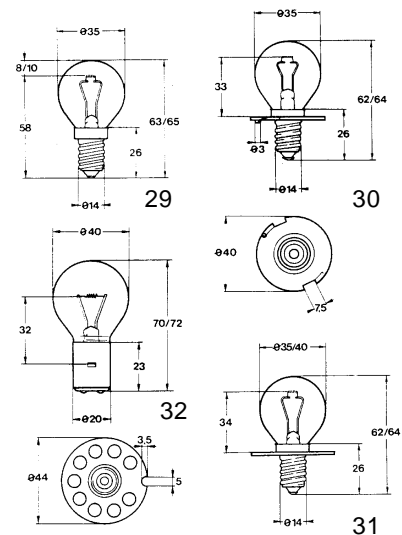

* = MATNÁ

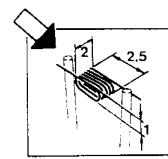
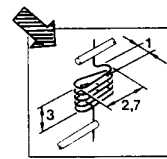
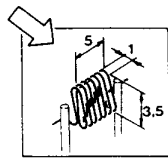
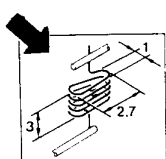
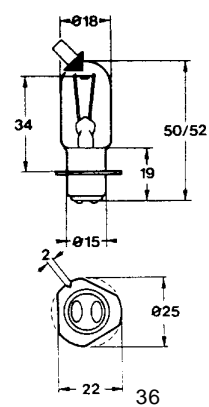
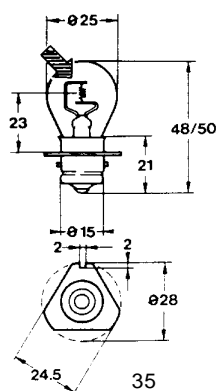
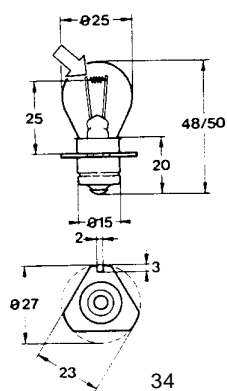
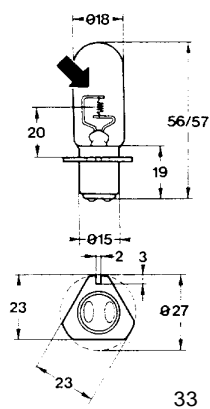

86.	3548/Z	39-01-86	6	50	P47D	500	120	37
87.	3647/L	39-01-53	6	25	P47D	300	100	38
88.	3746/Z	39-01-58	6	30	P47D	400	100	37

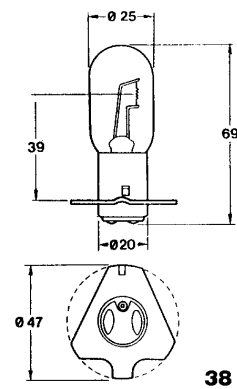
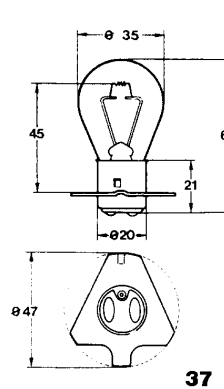

OBJ. ČÍSLO	KÓD	TYP	VOLT [V]	WATT [W]	PÁČICA	SVIETIVOSŤ [lm]	ŽIVOTNOSŤ [h]	OBRÁZOK č.
89.	2855	1730	6	15	P22D	130	100	37
90.	2954	1740	6	15	P25D/4	130	100	38
91.	3053	0P150	6	30	P35,5D	230	200	39
92.	3251	177160W	6	20	P21D	200	100	40
93.	3350/1	2107/B	6	15	MA.16	220	100	41
94.	3351/1	2107	6	15	MA.16	220	100	42
95.	3252/2	2107C	6	30	MA.16	220	100	42/A
96.	3252/3	2107D	6	15	MA.16	220	100	42/B
97.	3252/4	2107E	6	15	MA.16	220	100	42/C
98.	3430/1	13347	6	15	BA15D	130	100	43
99.	3430/2	-	6	30	BA15D	360	100	43
100.	3430/3	2113	6	18	BA15D	160	100	43
101.	3440	-	6	33	P 34D	430	80	43/A

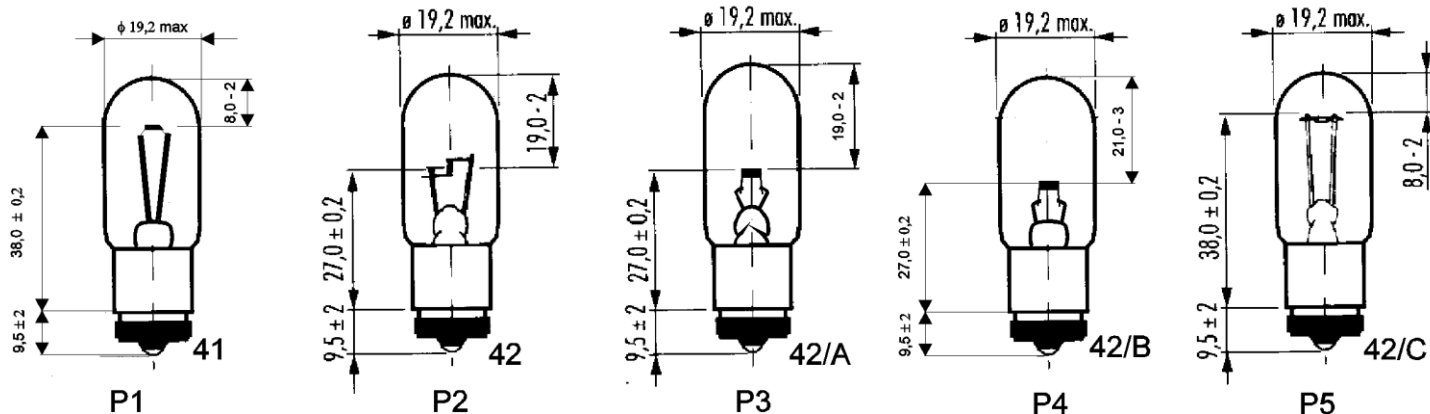
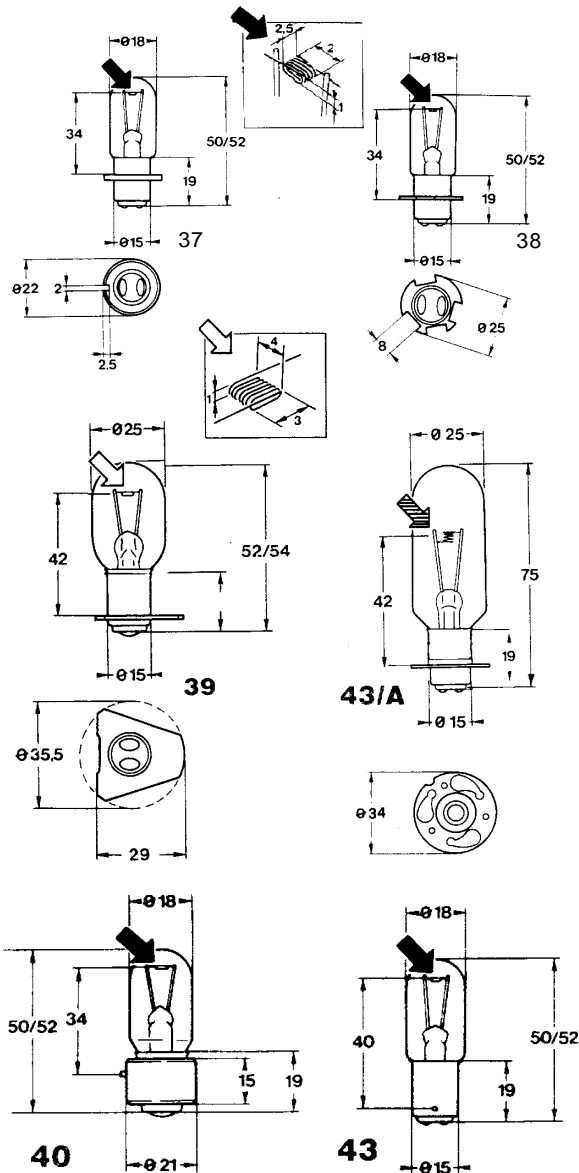



ISO 9001:2008, ISO 13485:2003

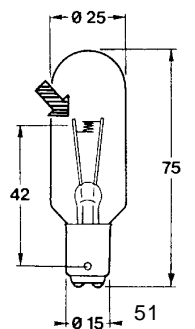
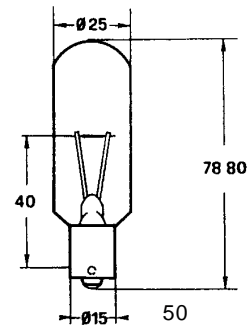
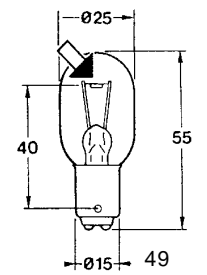
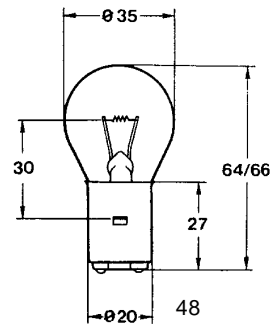
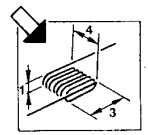
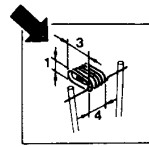
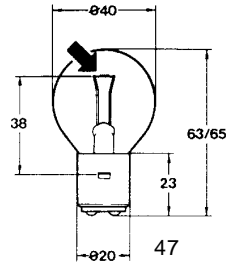
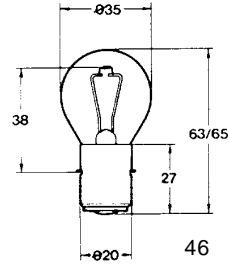

OBJ. ČÍSLO	KÓD	TYP	VOLT [V]	WATT [W]	PÁTICA	SVIETIVOSŤ [lm]	ŽIVOTNOSŤ [h]	OBRÁZOK č.
102.	3749/1	NA.	6	30	BA20D	400	100	46
103.	3749/2	8022	6	50	BA20D	500	120	46
104.	3770/3	2520	12	60	BA20D	1400	100	47
105.	3770/4	-	12	100	BA20D	1900	100	47
106.	3880/1	-	6	30	BA20D	330	100	48
107.	3880/2	-	6	50	BA20D	420	100	48
108.	3880/3	-	12	50	BA20D	1200	200	48
109.	3880/4	8029	15	60	BA20D	1500	100	48
110.	3890	2118	6	30	BA15D	230	200	49
111.	3891	7601	6	30	BA15S	600	100	50
112.	3892/1	2121	6	33	BA15D	430	80	51
113.	3893/1	2128 X	6	15	BA15D	180	100	52
114.	3893/2	2114	6	18	BA15D	220	100	52
115.	3893/3	2306	9	18	BA15D	240	100	52
116.	3893/4	2307	9	20	BA15D	250	100	52
117.	3893/NK	2129	6	15	P25D	180	100	52/A
118.	3894/1	2305	9	18	BA15S	240	100	53
119.	3894/2	2128X	6	15	BA15S	180	100	53
120.	3895/1	2305	9	18	P275	240	100	54

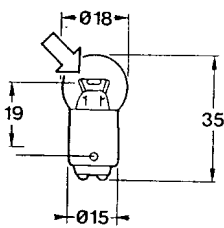

52

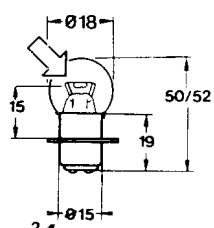

53

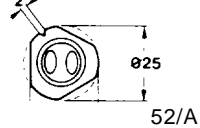

52/A

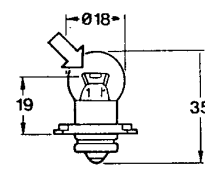
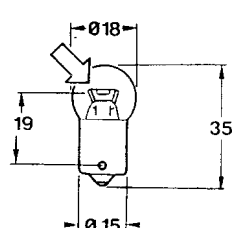

54

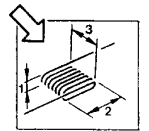
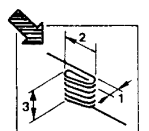
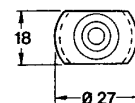

OBJ. ČÍSLO	KÓD	TYP	VOLT [V]	WATT [W]	PÁTICA	SVIETIVOSŤ [lm]	ŽIVOTNOSŤ [h]	OBRÁZOK č.
121.	3896/SP	3403	12	40	BA15S	-	100	55
122.	3897/0	2116	6	18	BA15D	-	100	56
123.	3897/5P	3601	220	20	BA15D	-	300	56
124.	3897/CH	-	220	30	BA15D	-	300	56/A
125.	3898/CH	-	220	15	E16	-	300	57
126.	3898/SM	-	220	15	E16	-	300	57
127.	3898/SM	-	220	15	E16	-	300	57/A
128.	3899/CH	-	220	20	E16	-	300	57
129.	3899/SM	-	220	20	E16	-	300	57
130.	3900/CH	-	220	15	E27	-	300	58
131.	3900/SM	-	220	15	E27	-	300	58
132.	3901/CH	-	220	25	E27	-	300	58
133.	3901/SM	-	220	25	E27	-	300	58
134.	4637/1	-	100	75	BA15S	1200	50	59
135.	4637/2	-	100	100	BA15S	1600	50	59
136.	4637/3	-	220	100	BA15S	-	50	59
137.	4637/SP	-	220	20	BA15D	-	300	59/A
138.	4637/SP	-	220	30	BA15D	-	330	59/A
139.	4835	-	220	90	E27	cd25	500	60
140.	4840/NK	-	220	30	BA15D	-	500	60/A
141.	4841/NK	-	220	20	BA15D	-	500	60/A

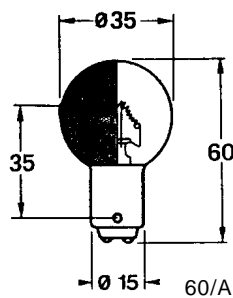
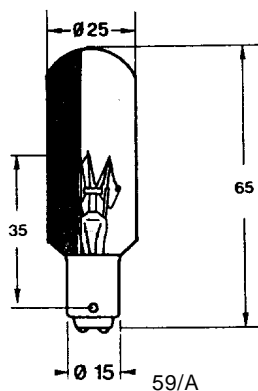
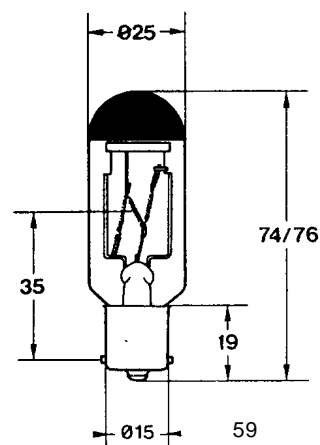
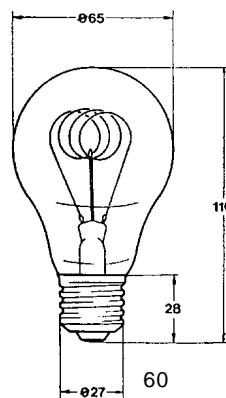
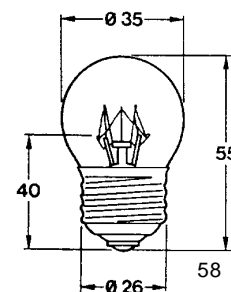
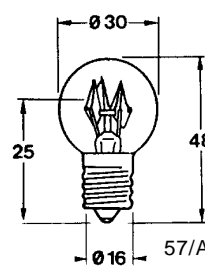
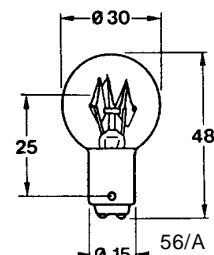
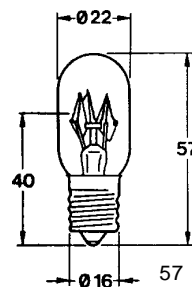
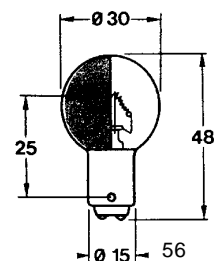
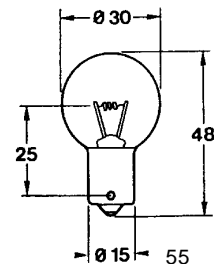

SP = POLOVICA ZRKADLOVÁ

CH = ČÍRA

OBI. ČÍSLO	KÓD	TYP	VOLT [V]	WATT [W]	PÁČICA	SVIETIVOSŤ [lm]	ŽIVOTNOSŤ [h]	OBRÁZOK č.
142.	5030/1	EZG	35	300	GEMINI	-	-	A
143.	5030/2	EZM	37,5	300	MARC	-	-	B
144.	5132/G	-	6	30	GZ6,35	-	500	61
145.	5132/0	1911	24	70	GZ6,35	-	1000	61
146.	5132/1	EFM	8	50	GZ6,35	-	50	61
147.	5132/2	EFN	12	75	GZ6,35	-	50	61
148.	5132/3	EFP	12	100	GZ6,35	-	50	61
149.	5132/4	EFR	15	150	GZ6,35	-	50	61
150.	* 5132/4A	-	15	150	GZ6,35	-	50	61
151.	5132/5	EKZ	10,8	30	GX5,3	-	50	62
152.	5132/6	EPZ	13,8	50	GX5,3	-	1000	62
153.	5132/7	DDM	19	80	GX5,3	-	50	62
154.	5132/8	DDL	20	150	GX5,3	-	500	62
155.	5132/9	EJM	21	150	GX5,3	-	40	62
156.	5132/10	ELD	21	150	GX5,3	-	40	62
157.	5132/11	EJA	21	150	GX5,3	-	40	62
158.	5132/12	EJL	24	200	GX5,3	-	25	62
159.	5132/13	ELC	24	250	GX5,3	-	50	62
160.	5132/14	ENX	82	350	GX5,3	-	75	62
161.	5132/15	ELH	120	300	GX5,3	-	35	62
162.	5132/16	EVW	82	250	GX5,3	-	50	62
163.	5132/17	FHS	82	300	GX5,3	-	35	62
164.	5330/1	DNF	21	150	GY7,9	-	25	63
165.	5330/2	DNE	120	150	GY7,9	-	12	63

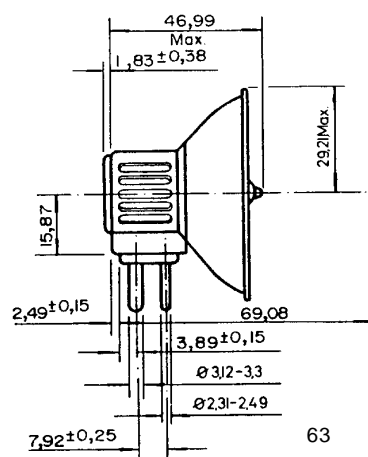
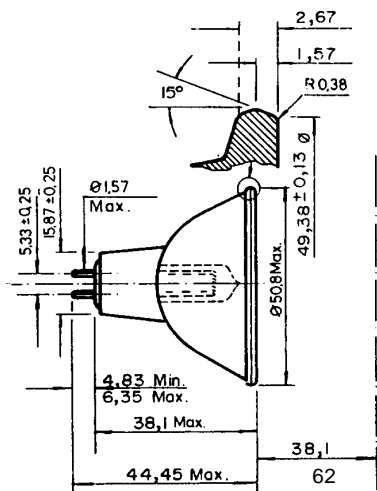
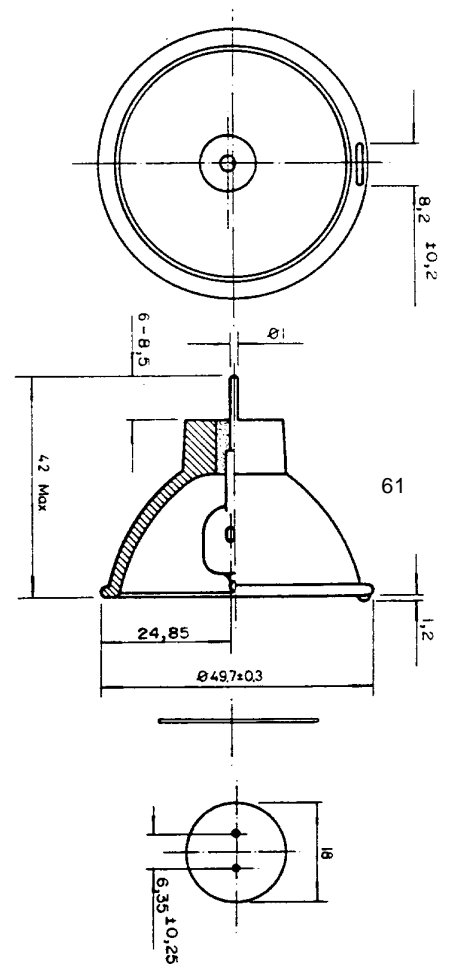
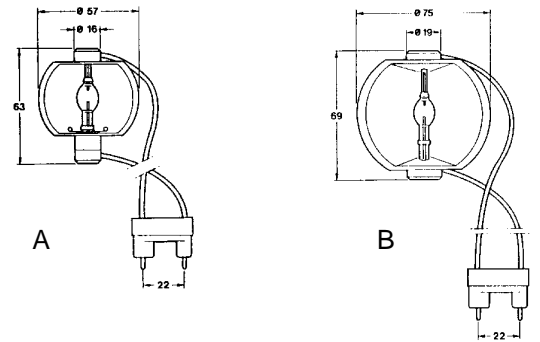

OBJ. ČÍSLO	KÓD	TYP	VOLT [V]	WATT [W]	PÁTICA	SVIETIVOSŤ [lm]	ŽIVOTNOSŤ [h]	OBRÁZOK č.
166.	5429/0	-	24	40	BA15D	-	500	-
167.	5429/1	-	24	50	BA15D	900	2000	64
168.	5429/2	-	24	150	BA15D	3500	1000	64
169.	542982B	-	24	100	BA15D	2200	2000	64
170.	5429/3	ESR	120	100	BA15D	1800	750	65
171.	5429/4	ESP	120	150	BA15D	2800	1000	65
172.	5429/5	ESS	120	250	BA15D	4850	2000	65
173.	5429/6	-	24	50	BA15D	900	2000	65
174.	5627/3	58915	24	60	PG22	900	2000	66
175.	5628/W1	64222	6	10	PG22	150	300	67
176.	5628/W2	64260	12	30	PG22	800	50	67
177.	5628/1	-	12	50	PG22	1500	50	68
178.	5628/2	64626	12	100	PG22	3000	50	68
179.	5629/1	29-100	12	20	P26	350	2000	69
180.	5629/2	705-0840	12	20	P15	350	2000	70
181.	5721/1	FDT	12	100	GY9,5	3000	50	71

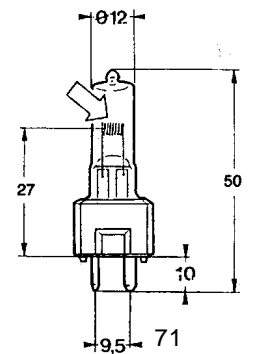
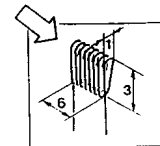
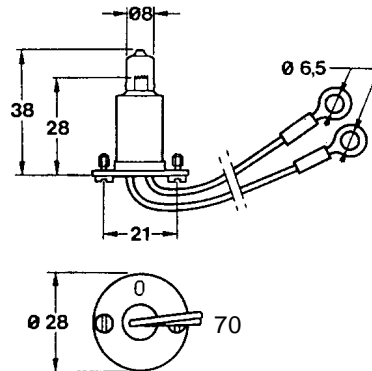
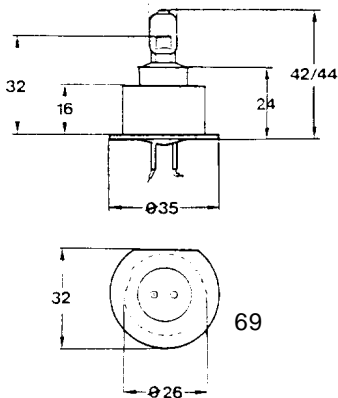
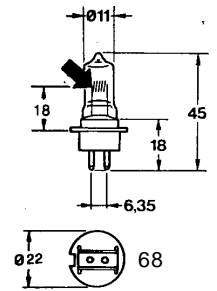
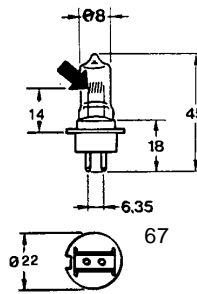
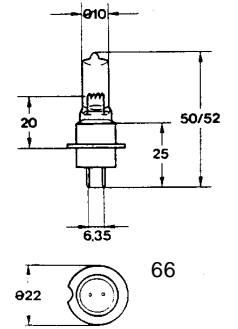
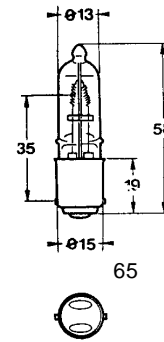
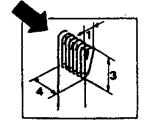
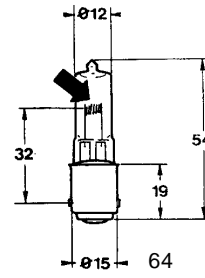

OBJ. ČÍSLO	KÓD	TYP	VOLT [V]	WATT [W]	PÁČICA	SVIETIVOSŤ [lm]	ŽIVOTNOSŤ [h]	OBRAZOK č.
182.	5722/1	FDS	24	150	GY9,5	5000	50	72
183.	5726/1	-	24	150	GY9,5	3400	800	73
184.	5726/2	-	24	220	GY9,5	4300	550	73
185.	5726/SM	P-129362-228	22	220	GY9,5	4100	500	73
186.	5727/SM	P-128249-001	33	230	GY9,5	5000	500	73
187.	5825/1	DYR	220	650	GY9,5	16500	50	74
188.	5825/2	DYP	120	600	GY9,5	17000	75	74
189.	5924/1	BRL	12	50	G.6, 35	1400	50	75
190.	5924/2	FCR	12	100	G.6,35	3000	50	75
191.	5924/3	BRJ	15	150	G.6.35	5000	50	75
192.	5924/4	FCS	24	150	G.6,35	5000	50	75
193.	5924/4A	-	24	150	G.6,35	4500	300	75
194.	5924/5	EHJ	24.	250	G.6,35	9500	50	76
195.	5924/5A	EVC	24	250	G.6,35	8400	300	76
196.	5924/SM	EVC	24	250	G.6,35	8200	300	76
197.	5924/6	EVD	36	400	G.6,35	14500	50	76
198.	5924/7	-	22,8	250	G.6,35	8000	500	76
199.	6023/1	-	24	100	X-514	2200	2000	77
200.	6023/2	H6950	24	120	X-514	3000	200	77
201.	6221/SM	104316	24	70	X-511	1250	2000	78
202.	6221/0	104316	24	70	X-511	1350	2000	78
203.	6221/1	104316	24	80	X-511	1600	1000	78
204.	6221/2	-	12	100	X-511	2500	1000	78
205.	6221/3	-	24	100	X-511	-	500	78
206.	6222/1	-	24	80	X-513	1600	1000	78/A

ISO 9001:2008, ISO 13485:2003

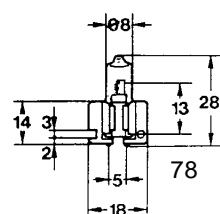
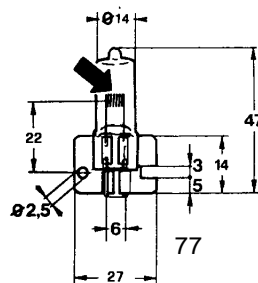
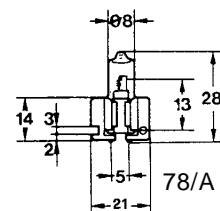
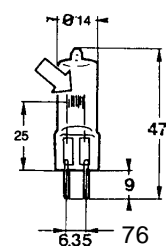
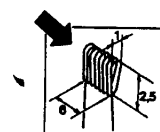
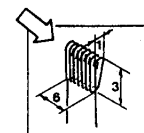
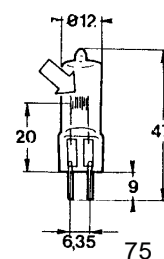
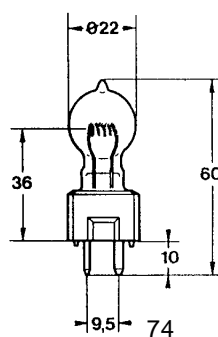
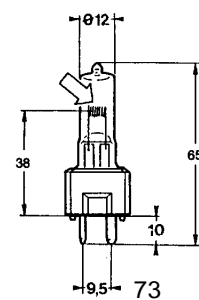
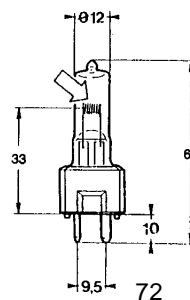

6023/2 - 3250 °K - 3000 LUMEN (77)

* SM = MATNÁ

OBJ. ČÍSLO	KÓD	TYP	VOLT [V]	WATT [W]	PÁTICA	SVIETIVOSŤ [lm]	ŽIVOTNOSŤ [h]	OBRÁZOK ě.
207.	6320/1	S.414Q	6	20	G.4	420	100	79
208.	6419/TS	1660	24	50	G.6,35	850	2000	80
209.	6419/1	905-24	24	100	G.6,35	2000	2000	80
210.	6419/TS	-	24	100	G.6,35	2200	2000	80
211.	6419/2	-	22,8	120	G.6,35	2800	300	81
212.	6419/2A	906-24	24	150	G.6,35	3200	2000	81
213.	641982B	-	24	220	G.6,35	4100	1000	81
214.	6419/3B	-	22,8	110	G.6,35	2600	1000	82
215.	6419/3	H018769	22,8	40	G.6,35	800	1000	82
216.	6419/3A	H018566	22,8	50	G.6,35	950	1000	82
217.	6419/4	H018576	24	50	G.6,35	1050	500	82
218.	6419/5	-	24	50	G.6,35	900	2000	82
219.	6518/0	-	6	10	G.4	140	1000	83
220.	6518/1	FHD	6	10	G.4	200	100	83
221.	6518/2	ESB	6	20	G.4	450	100	83
223.	6518/3	-	12	20	G.4	360	2000	83
224.	6518/4	-	24	20	G.4	350	2000	83
225.	6519/1	-	6	10	G.4	150	200	84
226.	6520/1	-	12	20	G.6,35	480	50	85
227.	6520/2	-	12	20	G.6,35	280	2000	85
228.	6520/3	-	12	30	G.6,35	750	50	85
229.	6601/0	AX	22,8	40	G.6,35	800	1000	86
230.	6601/1	AX	22,8	50	G.6,35	1100	1000	86
231.	6601/2	AX	24	55	G.6,35	1000	1000	86
232.	6601/TS	AX	24	55	G.6,35	1000	1000	86

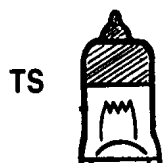

AX = AXIAL
TS = MATOVANÁ HLAVA

ISO 9001:2008, ISO 13485:2003

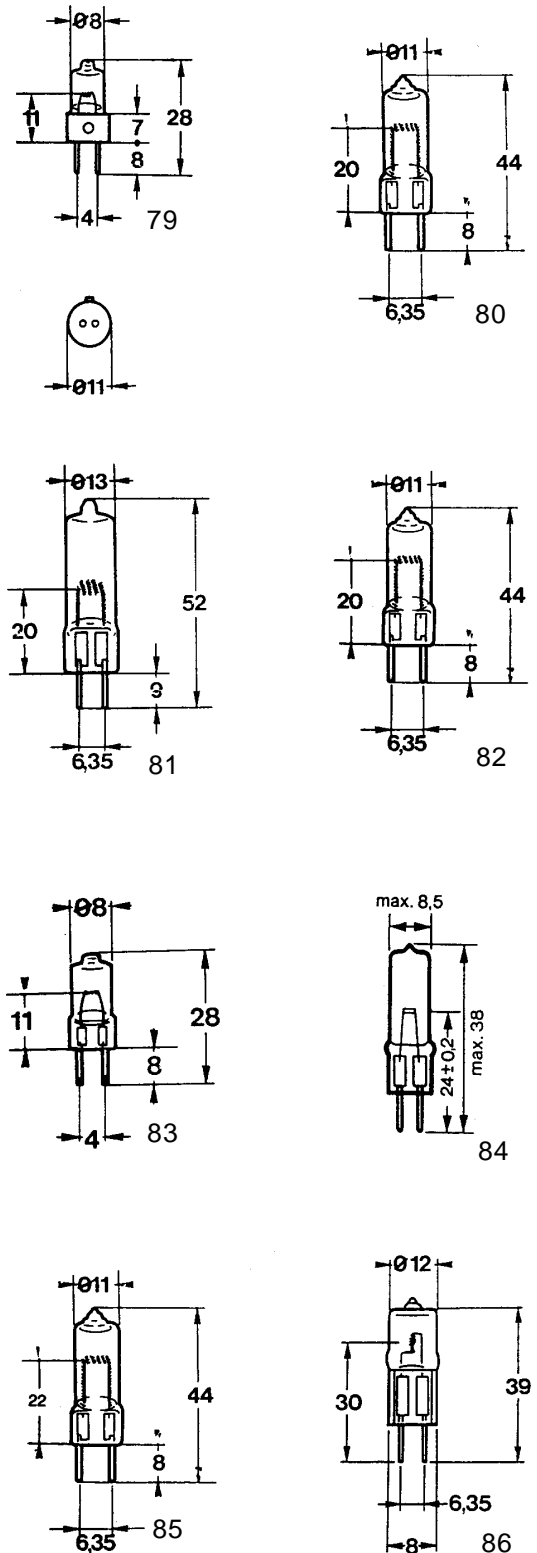

OBJ. ČÍSLO	KÓD	TYP	VOLT [V]	WATT [W]	PÁČICA	SVIETIVOSŤ [lm]	ŽIVOTNOSŤ [h]	OBRÁZOK č.
233.	6701/1	5H.37	24	35	E.11	750	500	87
234.	6701/2	5H.42	24	40	E.11	800	600	87
235.	6701/3	5H.52	24	50	E.11	1050	700	87
236.	6702/1	DKK24501	24	50	G.8	1000	500	88
237.	6703/1	-	24	50	G.6,35	900	1000	89
238.	6703/AX	-	24	55	G.6,35	1000	1000	89
239.	6704/TN	MILLION	24	40	G.8	800	700	90
240.	6704/TS	MILLION	24	50	G.8	1050	700	90
241.	6705/1	-	24	70	PK22	1350	1000	91
242.	6705/2	-	12	55	PK22	1200	1000	91
243.	6705/3	-	24	65	PK22	-	1000	91
244.	6708/TN	-	24	35	G.6,35	550	1000	92
245.	6709/1	H018366	22,8	75	R7S	1500	700	93
246.	6801/1	-	24	50	E11	900	2000	91/B

ISO 9001:2008, ISO 13485:2003

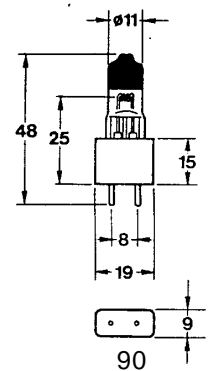
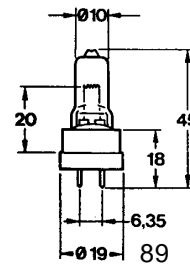
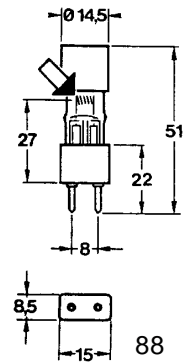
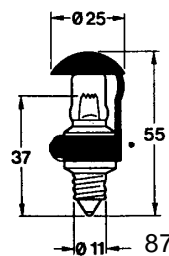
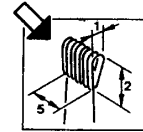

TN = ČIERNY VRCH
 TS = MATNÝ VRCH
 AX = AXIAL

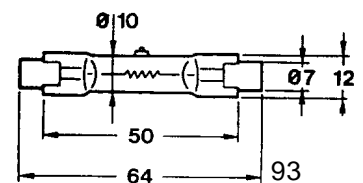
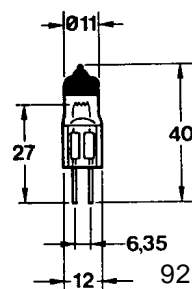
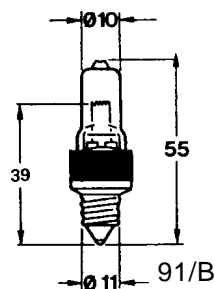
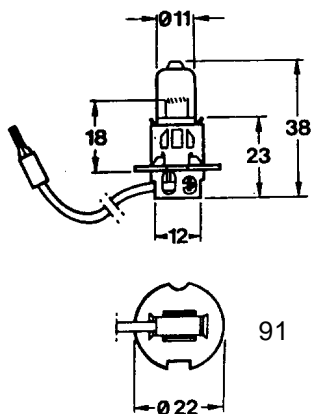

OBJ. ČÍSLO	KÓD	TYP	VOLT [V]	WATT [W]	PĀTICA	SVIETIVOSŤ [lm]	ŽIVOTNOSŤ [h]	OBRÁZOK č.
247.	7111/1	-	6	15	BA9S	110	100	92/A
248.	7113/1	-	6	6	BA9S	70	500	93/A
249.	7713/SM	-	6	6	BA9S	60	500	93/A
250.	7114/1	-	6	3	E10	30	500	94
251.	7114/SM	-	6	5	E10	55	500	94
252.	7114/3	-	6	5	E10	60	500	94
253.	7114/4	-	6	6	E10	70	500	94
254.	7114/5	-	8	5	E10	60	500	94
255.	7115/1	-	12	3	E10	22	500	94
256.	7115/SM	-	12	3	E10	20	500	94
257.	7115/SMA	-	6	1,8	-	-	-	94/A
258.	7116/H	HESS	3,5	-	E10	-	500	94
259.	7409/2	-	6	6	E.12M	70	500	95
260.	7500/1	-	6	15	E10	110	100	96
261.	7501/2	-	6	15	BA9S	110	100	96/A

GERMICÍDNE TRUBICE

GERMICÍDNE TRUBICE UV 253,7 nm

TYP	WATT [W]	VOLT [V]	PĀTICA	W pri 254nm (W)	ROZMERY L[mm] d[mm]	ŽIVOTNOSŤ	OBRÁZOK
TUV 6W-E	6	220	E27	0,1	157,5x27,5	2500	96
TUV 15WL L	15	-	G13	4,0	438x26	8000	96
TUV 30WL L	30	-	G13	10,0	895x26	8000	96
TUV 36WL L	36	-	G13	14,0	1200x26	8000	96
TUV 55WL L	55	-	G13	17,0	895x26	8000	96

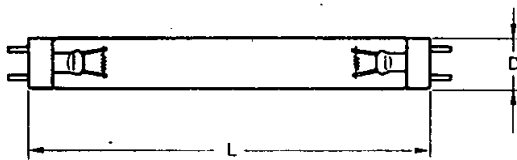

96

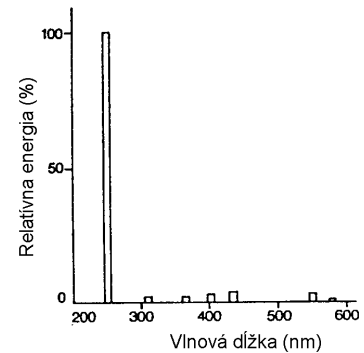
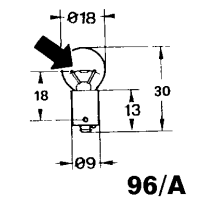
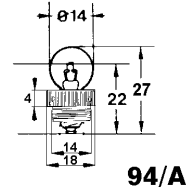
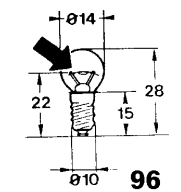
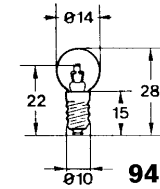
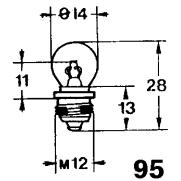
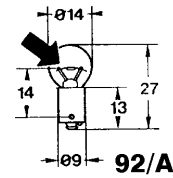
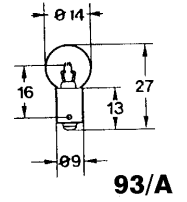
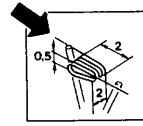

OBJ. ČÍSLO	KÓD	TYP	VOLT [V]	WATT [W]	PÄTICA	SVIETIVOSŤ [lm]	ŽIVOTNOSŤ [h]	OBRÁZOK č.	
262.	55122	HLWS5	6	6	10	PY16-1,25	195	100	108
263.	55125	HLWS5	6	6	10	PY16-1,25	150	100	108
264.	55133	HLWS5	6	6	20	PY16-1,25	450	100	108
265.	55147	HLWS5-A	6	6	25	PY16-1,25	510	100	108
266.	55149	HLWS5	6	6	25	PY16-1,25	525	75	108
267.	55127	HLWS5	12	12	10	PY16-1,25	140	50	108
268.	55140	HLWS5-A	12	12	20	PY16-1,25	350	1000	108
269.	55204	HLWS5	12	12	50	PY24-1,5	1400	50	109
270.	55205	HLWS5-A	12	12	50	PY24-1,5	1400	50	109
271.	55305	HLWS5	12	12	100	PY24-1,5	3000	50	109
272.	55307	HLWS5-A	12	12	100	PY24-1,5	3000	50	109
273.	55405	HLWS5	24	24	150	PY24-1,5	5000	50	110
274.	55503	HLWS5	24	24	250	PY24-1,5	8500	50	111
275.	55507	HLWS5-A	24	24	250	PY24-1,5	8500	50	111
276.	55606	HLWS5	36	36	400	PY24-1,5	14500	50	112
277.	57055	HLWS5-P	24	24	200	PY24-1,5	5500	300	113

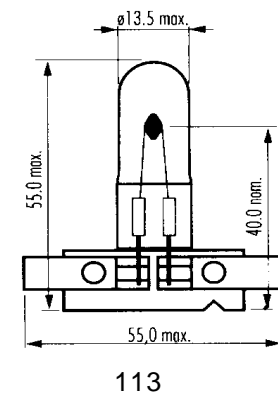
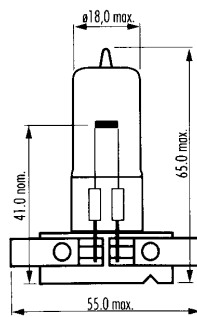
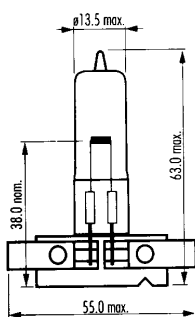
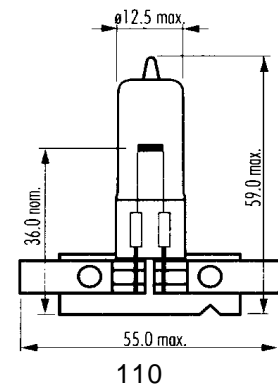
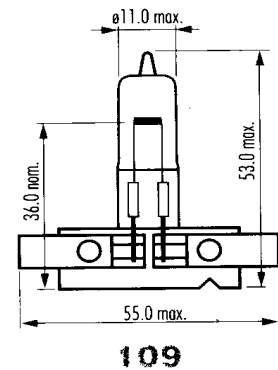
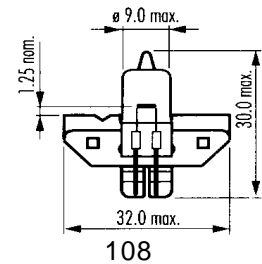

PÄTICE



ISO 9001:2008, ISO 13485:2003

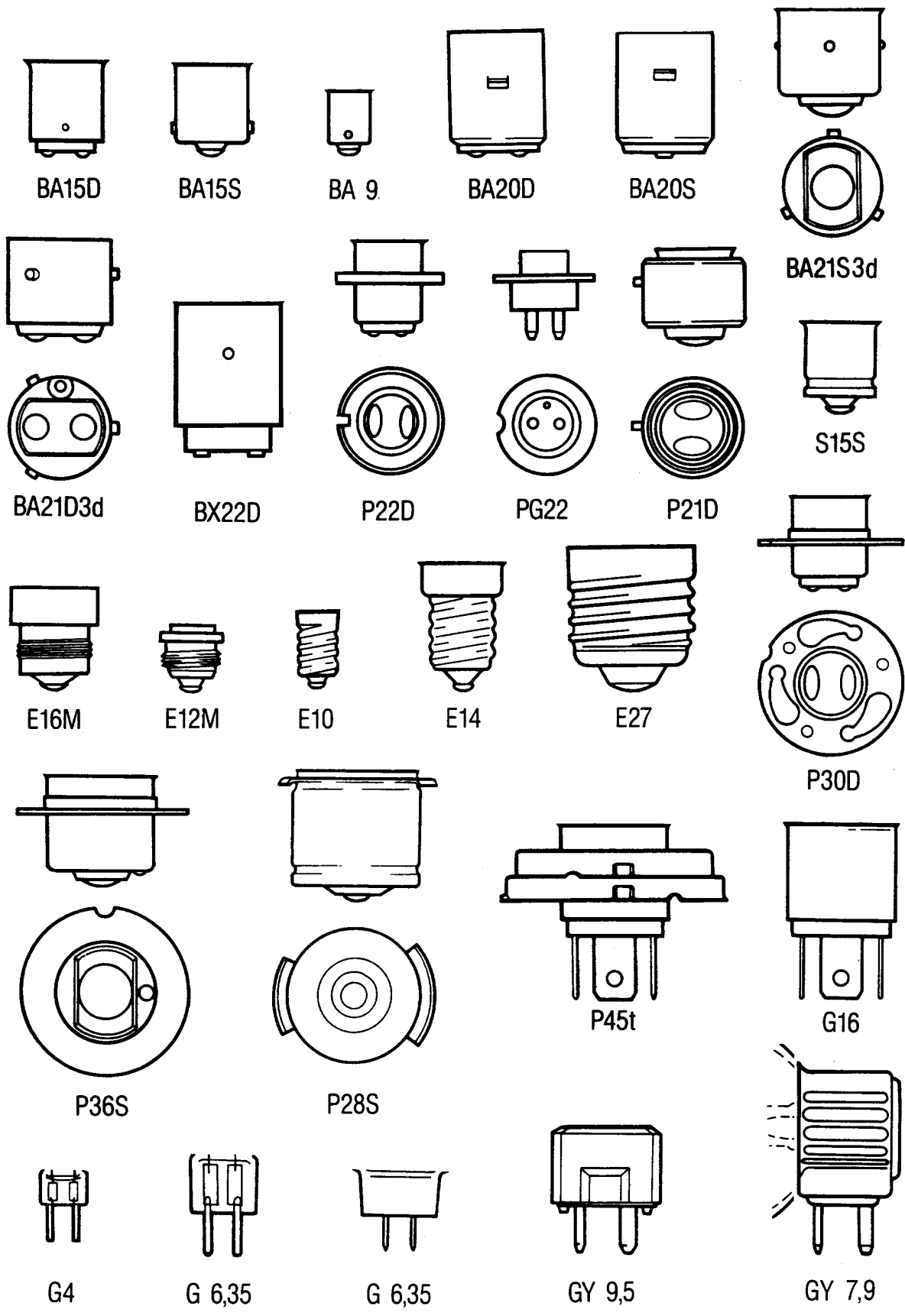

Číslo	Typ	Ekvivalent	Volt [V]	Prístroj	Obrázok č.	Mierka
-------	-----	------------	----------	----------	------------	--------



ISO 9001:2008, ISO 13485:2003

278. 503 WELCH ALLYN 2,5 laryngoskop 114. 1:1



279. 504 WELCH ALLYN 2,5 otoskop 115. 1:1



280. 505 WELCH ALLYN 2,5 oftalmoskop 116. 1:1



281. 506 WELCH ALLYN 2,5 oftalmoskop 117. 1:1



282. 507 WELCH ALLYN 2,5 illuminator 118. 1:1



283. 508 WELCH ALLYN 2,5 oftalmoskop 119. 1:1

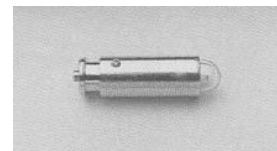

284. 510 WELCH ALLYN 6 vyšetrovacie svetlo 120. 1:1



285. 511 WELCH ALLYN 3,5 retinoskop, oftalmoskop 121. 1:1



286. 512 WELCH ALLYN 3,5 oftalmoskop 122. 1:1



287. 513 WELCH ALLYN 3,5 otoskop,iluminator 123. 1:1



Číslo	Typ	Ekvivalent	Volt [V]	Prístroj	Obrázok č.	Mierka
-------	-----	------------	----------	----------	------------	--------

288.	514	WELCH ALLYN	-	oftalmoskop	124.	1:1
289.	515	WELCH ALLYN	2,5	otoskop, wa iluminator	125.	1:1
290.	516	WELCH ALLYN	3,5	retinoskop	126.	1:1
291.	517	WELCH ALLYN	-	oftalmoskop	127.	1:1
292.	518	WELCH ALLYN	6	penlite	128.	1:1
293.	519	WELCH ALLYN	-	diagnostická lampa	129.	1:1
294.	520	WELCH ALLYN	3,5(2,5)	retinoskop	130.	1:1
295.	521	WELCH ALLYN	2,5	retinoskop	131.	1:1
296.	522	WELCH ALLYN	-	laryngoskop	132.	1:1
297.	523	WELCH ALLYN	3,5	audioskop	133.	1:1

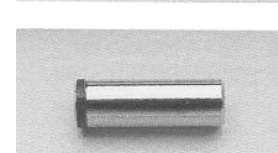
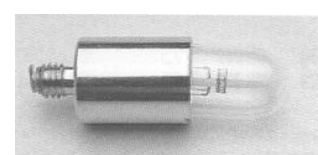
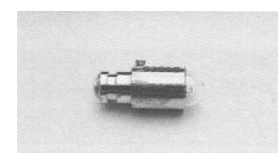

Číslo	Typ	Ekvivalent	Volt [V]	Prístroj	Obrázok č.	Mierka
-------	-----	------------	----------	----------	------------	--------



ISO 9001:2008, ISO 13485:2003

298.	524	WELCH ALLYN	2,5	vláknový laryngoskop	134.	1:1
299.	525	WELCH ALLYN	2,7	laryngoskop, otoskop	135.	1:1
300.	526	WELCH ALLYN	2,5	halogen	136.	1:1
301.	527	WELCH ALLYN	5	"Q" halogen	137.	1:1
302.	528	WELCH ALLYN	2,5/3,6	"R" halogen	138.	1:1
303.	529	WELCH ALLYN - HEINE	2,2	otoskop	139.	1:1
304.	530	HEINE	2,5/3,5	autofokus, oftalmoskop	140.	1:1
305.	531	HEINE	2,5	alfa iluminačné šošovky	141.	1:1
306.	532	HEINE	2,5/3,5	otoskop	142.	1:1
307.	533	HEINE	2,5/3,5	otoskop	143.	1:1

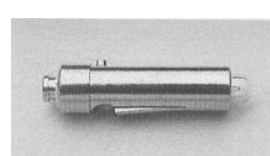
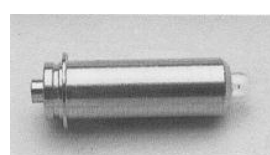
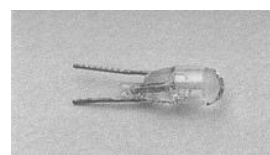

Číslo	Typ	Ekvivalent	Volt [V]	Prístroj	Obrázok č.	Mierka
-------	-----	------------	----------	----------	------------	--------

308.	534	HEINE	2,5/3,5	oftalmoskop	144.	1:1
309.	535	HEINE	2,5/3,5	focalux	145.	1:1
310.	536	HEINE	2,5/3,5	proctoscope	146.	1:1
311.	537	HEINE	2,5	mini fibralux otoskop	147.	1:1
312.	538	HEINE	2,5	oftalmoskop	148.	1:1
313.	539	HEINE	2,5	očná lampa	149.	1:1
314.	540	HEINE	2,5	minilux otoskop	150.	1:1
315.	541	HEINE	2,5	retinoskop	151.	1:1
316.	542	HEINE	2,5	laryngoskop	152.	1:1
317.	543	HEINE	2,5/3,5	oftalmoskop	153.	1:1

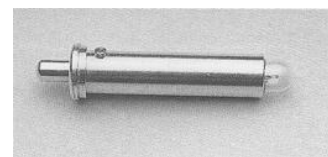
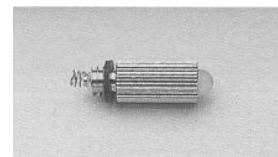
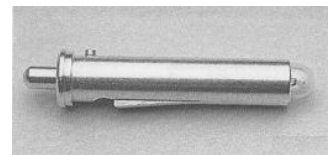

Číslo	Typ	Ekvivalent	Volt [V]	Prístroj	Obrázok č.	Mierka
-------	-----	------------	----------	----------	------------	--------



ISO 9001:2008, ISO 13485:2003

318.	544	HEINE	2,5/3,5	dermatoskop	154.	1:1
------	-----	-------	---------	-------------	------	-----



319.	545	HEINE	3,5	skiaskop	155.	1:1
------	-----	-------	-----	----------	------	-----



320.	546	HEINE	3,5/6	oftalmoskop	156.	1:1
------	-----	-------	-------	-------------	------	-----

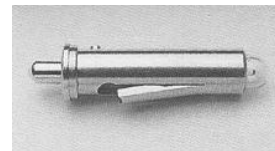

321.	547	HEINE	6	oftalmoskop sigma 100	157.	1:1
------	-----	-------	---	-----------------------	------	-----



322.	548	HEINE	6	ručná lampa	158.	1:1
------	-----	-------	---	-------------	------	-----



323.	549	HEINE	6	oftalmoskop	159.	1:1
------	-----	-------	---	-------------	------	-----



324.	550	HEINE	6	binokulárna lupa	160.	1:1
------	-----	-------	---	------------------	------	-----

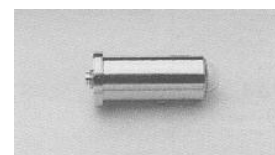

325.	551	HEINE	2,5/4,0	ofallmoskop	161.	1:1
------	-----	-------	---------	-------------	------	-----



326.	552	HEINE	2,5/3,5	retinoskop	162.	1:1
------	-----	-------	---------	------------	------	-----

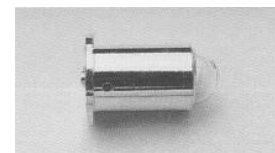

327.	553	HEINE	2,5/3,5	retinoskop	163.	1:1
------	-----	-------	---------	------------	------	-----

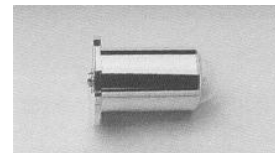

Číslo	Typ	Ekvivalent	Volt [V]	Prístroj	Obrázok č.	Mierka
-------	-----	------------	----------	----------	------------	--------



ISO 9001:2008, ISO 13485:2003

328.	554	HEINE	2,5/4,0	rektoskop	164.	1:1
329.	555	HEINE	2,5	otoskop	165.	1:1
330.	556	HEINE	2,5	otoskop	166.	1:1
331.	557	MC INTOSCH	2,7	laryngoskop	167.	1:1
332.	558	MC INTOSCH	2,7	laryngoskop	168.	1:1
333.	559	PENLON	2,7	laryngoskop	169.	1:1
334.	560	DR.SALING	2,5	laryngoskop	170.	1:1
335.	561	FORE GGER ET MILLER	2,5	laryngoskop	171.	1:1
336.	562	TUTTLINGER	2,7	otoskop	172.	1:1
337.	563	RIMMER	2,5	bronchoskop	173.	1:1

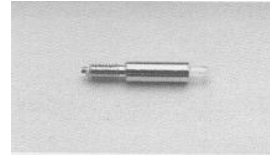
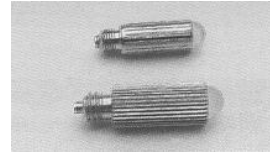
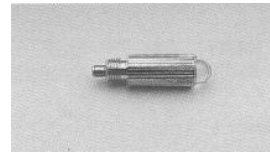
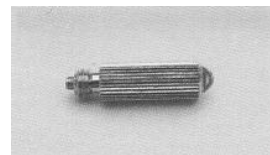

Číslo	Typ	Ekvivalent	Volt [V]	Prístroj	Obrázok č.	Mierka
-------	-----	------------	----------	----------	------------	--------



ISO 9001:2008, ISO 13485:2003

338.	564	PILLING	3,5	bronchoskop	174.	1:1
339.	565	ACMI	2,5	cysto-uretro laryngoskop	175.	1:1
340.	565	ACMI	2,5	otoskop	176.	1:1
341.	567	ACMI	2,5	proktoskop	177.	1:1
342.	568	BOEHM	2,5/4	otoskop	178.	1:1
343.	569	GOWLAND	2,5	otoskop	179.	1:1
344.	570	EFFNER	2,5	laryngoskop	180.	1:1
345.	571	CLAR	4/6/9	oftalmoskop	181.	1:1
346.	572	SCHARRAS	-	laryngoskop	182.	1:1
347.	573	FRENZEL	3,8	-	183.	1:1

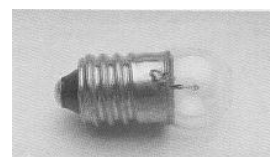
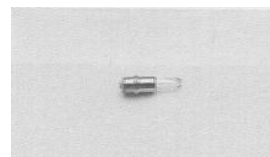

Číslo	Typ	Ekvivalent	Volt [V]	Prístroj	Obrázok č.	Mierka
-------	-----	------------	----------	----------	------------	--------

348.	574	DR ROSCHUE	3,8	analspekulum	184.	1:1
349.	575	MORGAN	3,5	protoskop rektoskop	185.	1:1
350.	576	HEYNEMANN	4	cystoskop	186.	1:1
351.	577	STORZ	2,5	laryngoskop	187.	1:1
352.	578	STORZ	6	vyšetr. lampa	188.	1:1
353.	579	JANSEN	4/8/10/3,5	vyšetr. lampa	189.	1:1
354.	580	LUNEAU	2,5	oftalmoskop	190.	1:1
355.	581	LUNEAU	3,8	oftalmoskop	191.	1:1
356.	582	LUNEAU	3,8	oftalmoskop	192.	1:1
357.	583	LUNEAU	3,7	retinoskop	193.	1:1

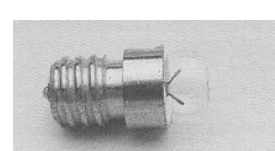
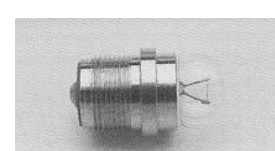
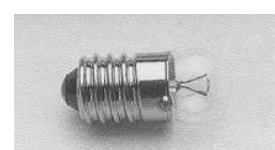
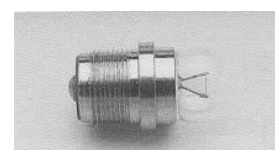
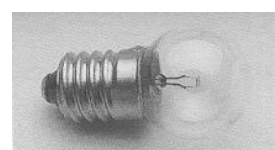
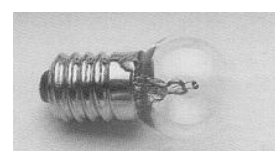

Číslo	Typ	Ekvivalent	Volt [V]	Prístroj	Obrázok č.	Mierka
-------	-----	------------	----------	----------	------------	--------



ISO 9001:2008, ISO 13485:2003

358.	584	MEDILUX	2,5/3,8	otoskop	194.	1:1
359.	585	EFFNER	2,7/4,0	rektoskop	195.	1:1
360.	586	EFFNER	2,7/3,8	analspekulum	196.	1:1
361.	587	RIESTER N°3900	2,7	otoskop	197.	1:1
362.	588	RIESTER N°3950	2,5	oftalmoskop	198.	1:1
363.	589	MAY/RIESTER N°3910	2,7	oftalmoskop	199.	1:1
364.	590	FRENZEL	3,8	oftalmoskop	200.	1:1
365.	591	NATIONAL ELEKTRIC	2,5	oftalmoskop	201.	1:1
366.	592	EFFNER	4,0	amnioskop	202.	1:1
367.	595	REICHART	6V/30W	mikroskop	203.	1:1

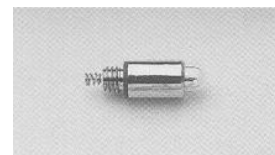

Číslo	Typ	Ekvivalent	Volt [V]	Prístroj	Obrázok č.	Mierka
-------	-----	------------	----------	----------	------------	--------



ISO 9001:2008, ISO 13485:2003

368.	596	TOPCON	230V/15	lensmeter	204.	1:1
------	-----	--------	---------	-----------	------	-----

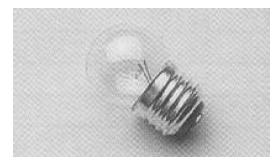

369.	RVK 125		220/7W	výbojky pre ortuťové horské slnká	205.	1:1
------	------------	--	--------	-----------------------------------	------	-----

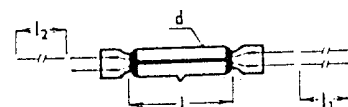

370.	RVK 400		220/24W	výbojky pre ortuťové horské slnká	206.	1:1
------	------------	--	---------	-----------------------------------	------	-----

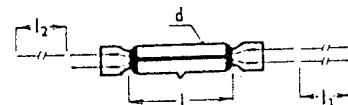

371.	HIY		230/1000 W	halogénové žiarovky pre infratechniku	207.	1:1
------	-----	--	---------------	---------------------------------------	------	-----

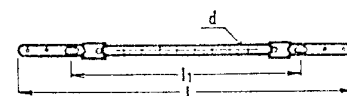

626 Typ HBO Mikroskopy, endoskopy

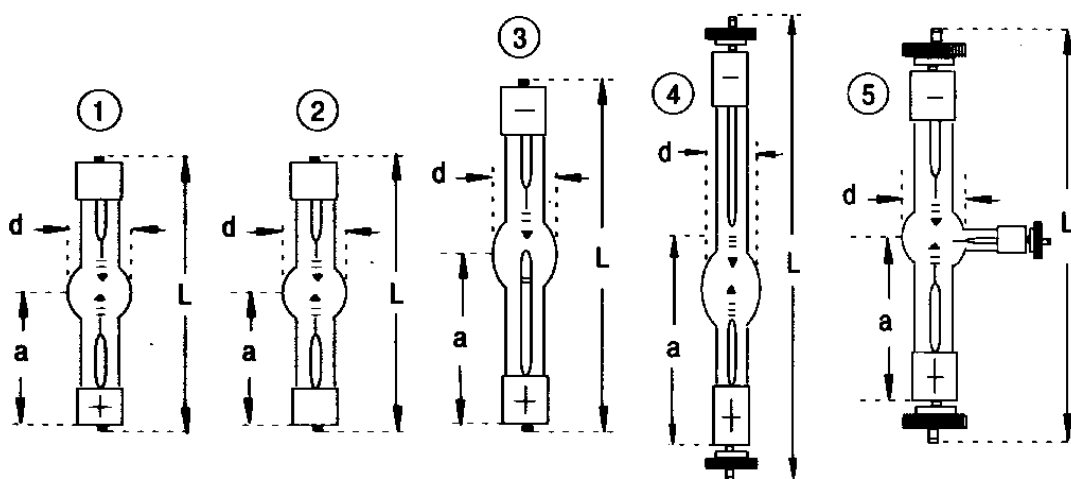
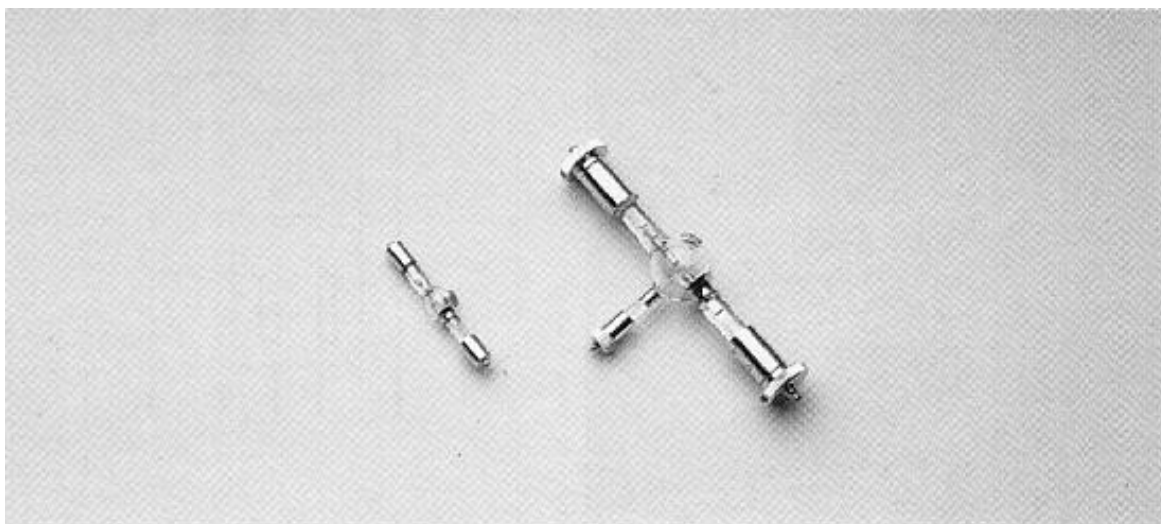

Číslo	Kód	Eivalent	Volt [V]	Ampér [A]	Watt [W]	Svietivosť [lm]	Rozmery (mm)			Životnosť [h]	Obrázok č.
							[d]	[L]	[a]		

130	776	H 50W/3	22 VDC	2,3	50	1300	9,5	53	22	200	1
130	774	H 50W/AC L1	39/45 VAC	1,3	50	2000	9,5	53	22	100	2
130	775	H 50W/AC L2	34/39 VAC	1,45	50	2000	9,5	53	22	100	2
130	780	H 100W/2	20 VDC	5	100	2500	10	903	43	200	3
130	782	H 200W/2 L1	61/53 AC/DC	3,6	200	10000	17	125	40	200	4
130	787	H 200W/2 L2	61/53/AC/DC	4,2	200	10000	17	125	40	200	4
130	790	H 200W/DC	57 VDC	3,5	200	10000	17	125	40	1000	4
130	784	H 200W/4	61 VDC	3,6	200	9500	17	125	40	200	4
130	800	H 200W	61/53 AC/DC	3,6/4,2	200	9500	18	108	40	200	5*

627 Typ HTI endoskop

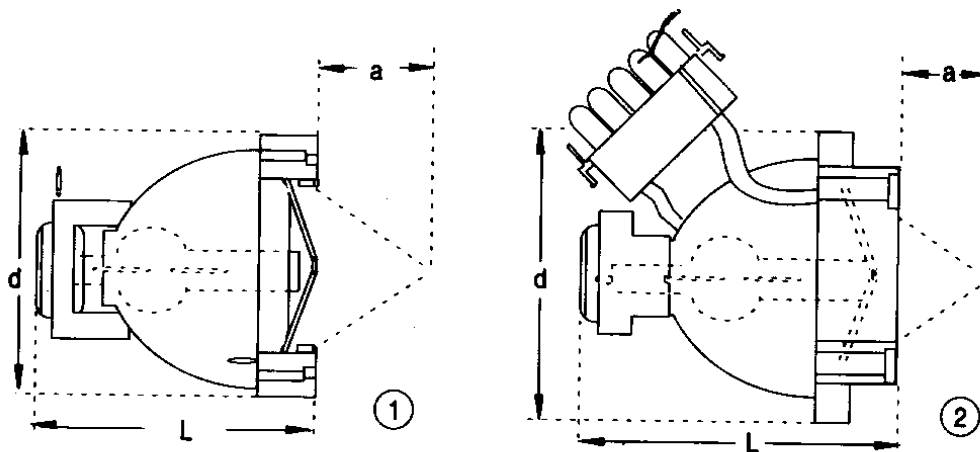
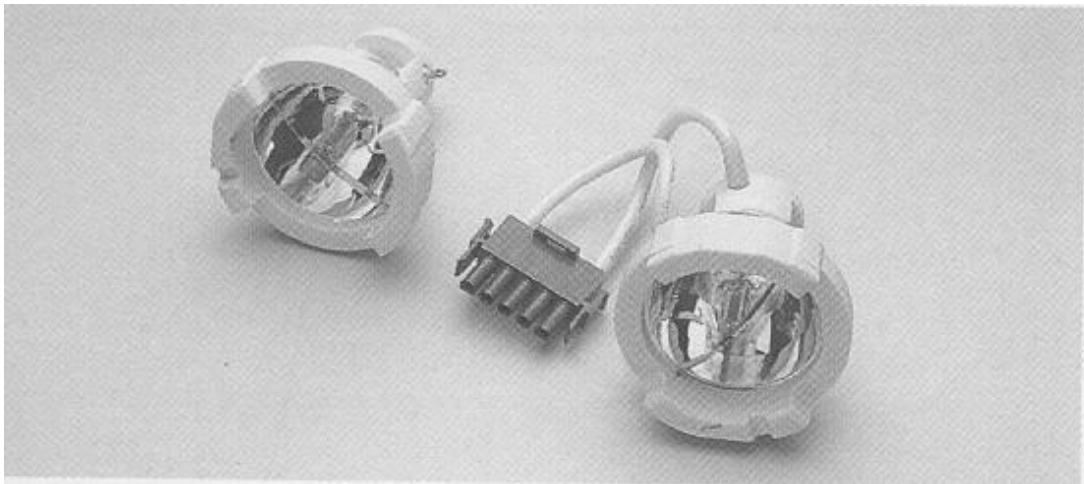

Číslo	Kód	Ekivalent	Volt	Ampér	Watt	Teplota farby	Rozmery	Životnosť	Obr.
			[V]	[A]	[W]	[° KELVIN]	[d×L mm] a	[h]	č.

008	487	HTI 250/22 FS	45	6 A	270	5600 °K	67x73	22	250	1
008	477	HTI 250/32 C	45	6 A	270	5600 °K	67x73	32	250	2
008	479	HTI 250/32	45	6 A	270	5600 °K	67x73	32	250	1
008	478	HTI 400/24	55	7,3 A	400	5600 °K	24x73	24	250	2

FS: pre optické vlákno

C: s káblom